



Containers for selective waste collection

Recycling banks



-
- Polyester (GRP) banks
 - Collection banks made from PE
 - Semi-underground containers
 - Collection banks made from steel

Polyester (GRP) banks

GFA 1.5 - 2.5 - 3.2

GFB 1.3 - 2.5 - 3.3



GFA and GFB collection banks represent well-proven method of selective collection of municipal waste.

They meet the highest standards for easy, comfortable and safe waste collection and comply to EN 13071. Quality is guaranteed by a five-year warranty, which we could hardly offer without using high-quality materials and superior surface treatment.

Emptying

- the container is lifted by a hydraulic crane and is emptied through its bottom into a garbage collection truck,
- A-type – bottom hinges are positioned on the container perimeter,
- B-type – bottom hinges are positioned on a joint central bracket,
- drawbars inside the container for paper or plastic collection are positioned along the inner walls for easy emptying.



Specification

- manufactured from glassfibre with high mechanical strength,
- all steel components are hot-dip galvanized,
- weather and chemical resistance,
- logos, inscriptions, numbers etc. laminated straight into container surface,
- available in any color,
- intended for the collection of sorted solid municipal waste.



GFB 2.5

type	width [mm]	depth [mm]	height [mm]
GFB 1.3	1200	1200	1550
GFB 2.5	1400	1400	1760
GFB 3.3	1680	1680	1760





GFA 1.5 -2.5

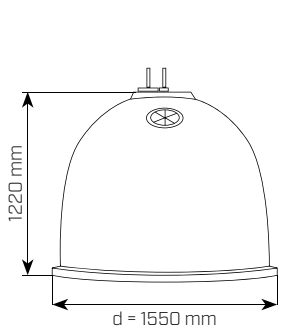

GFA 1.5

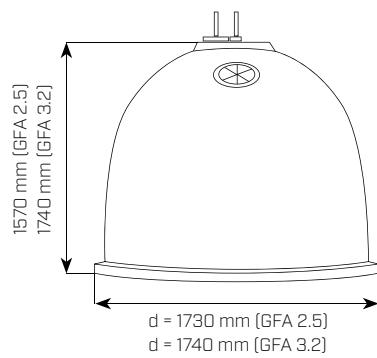

GFA 2.5, GFA 3.2

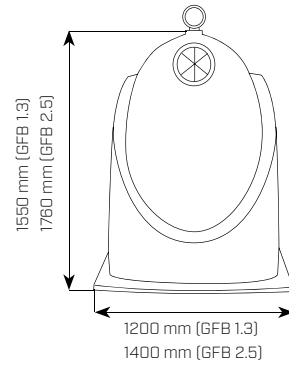

GFB 1.3, GFB 2.5

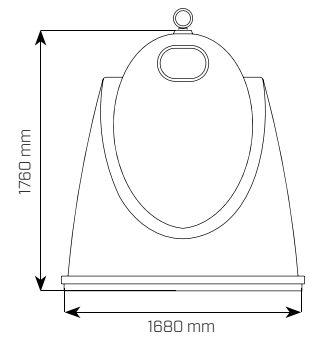

GFB 3.3



GFA 2.5 DUO



GFA 1.5 -2.5



GFA 3.2



GFB 2.5 DUO



GFA 2.5 inspection window

type	diameter [mm]	height [mm]
GFA 1.5	1550	1220
GFA 2.5	1730	1570
GFA 3.2	1740	1740

Polyester (GRP) banks

GFA 3.0, 3.3, 4.0

GFB 3.5, 4.7, GFA 300, 900



Main advantages

- encourage selective sorting of municipal waste,
- space-saving arrangement compared to 1100-litre containers,
- easy and efficient waste collection (one-man operation),
- extreme weather resistance and high shape stability,
- aesthetic design,
- easy cleaning and graffiti removal.

Options

- non-flammable construction,
- noise-reduction for glass collection,
- multi-compartment construction (Duo, Triglo models),
- various emptying systems (Kinshofer, pedal and others),
- customized throw-in holes.



GFA 3.3



GFA 3.3 DUO



GFA 3.3



GFA 3.3 DUO

type	width (mm)	depth (mm)	height (mm)
GFA 3.0	1520	1610	1690
GFA 3.3	2100	1700	1650
GFA 4.0	1920	1610	1690



GFB 4.7

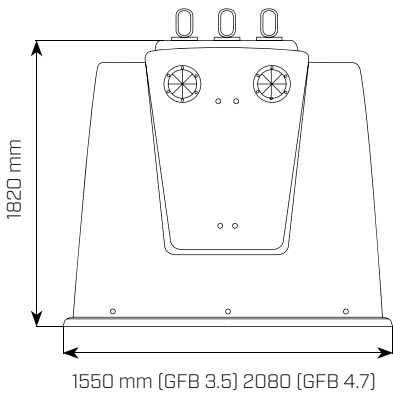

GFB 3.5, GFB 4.7

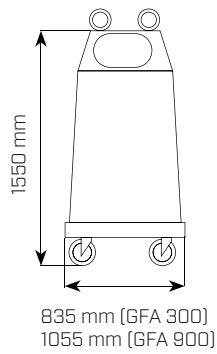

GFA 300, GFA 900



GFB 3.5 TRIGLO



GFA 900

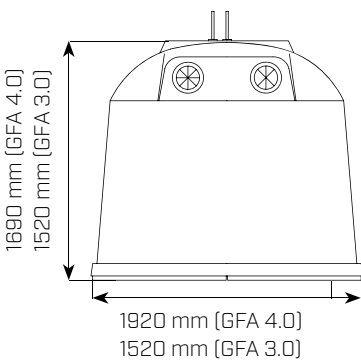

GFA 4.0, 3.0

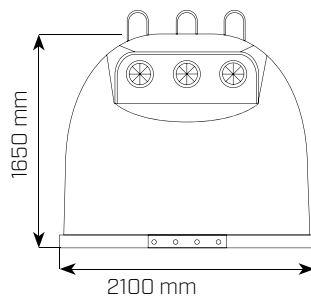

GFA 3.3



GFB 4.7 DUO



GFA 3.0, 4.0

type	width (mm)	depth (mm)	height (mm)
GFB 3.5	1550	1830	1820
GFB 4.7	2080	1830	1820
GFA 300	835	600	1550
GFA 900	1055	840	1550

Collection banks made from PE

KTS 1.5, 2.1, 2.5, ROTOBELL 2.5, 3.3



The KTS/ROTOBELL container range represents a suitable solution for collection of sorted waste. It incorporates an approved concept of bottom emptying and unique appearance. Their platform enables efficient use of the collection point area.

High-quality polyethylene granulate without recycled admixtures is used in the container production. All steel components are hot-dip galvanized. They are fully recyclable, once their life-time is over. Our solution of the waste paper and plastic version (generally bulky waste) provides trouble-free emptying. It consists in a thorough guidance of the emptying system alongside inner walls (as compared with the mechanism guided through the centre of the container inner space).



Emptying mechanism - glass



Emptying mechanism - paper, plastics

Customisation

- embossed logo or inscription,
- fully colored logo or inscription in the container mass, the advantage is permanency and ease of cleaning.



KTS 2.1



KTS 1.5



KTS 1.5 - inlet hole detail



KTS 2.5 DUO



ROTOBELL 3.3

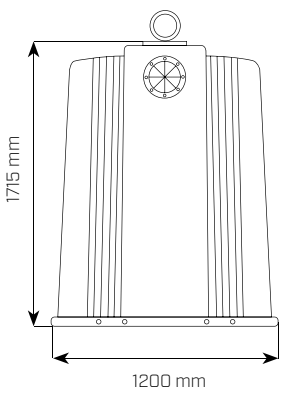

KTS 2.1

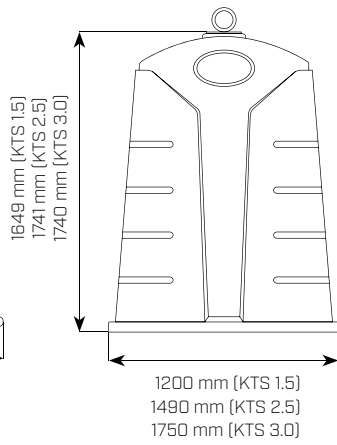

KTS 1.5, 2.5, 3.0

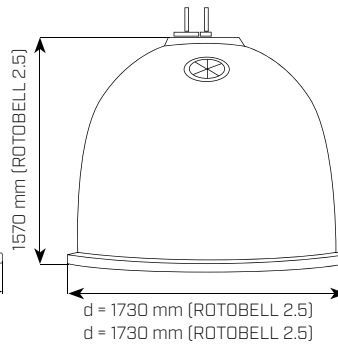

ROTOBELL 2.5

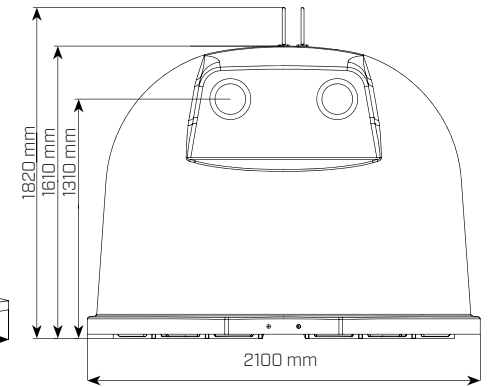

ROTOBELL 3.3



KTS 1.5

type	width (mm)	depth (mm)	height (mm)
KTS 1.5	1200	1200	1649
KTS 2.1	1200	1400	1715
KTS 2.5	1490	1490	1741
KTS 3.0	1750	1490	1740
ROTOBELL 2.5	1730	1730	1570
ROTOBELL 3.3	2100	1720	1610



Semi-underground containers

SemiQ 1.5, 3.0, 5.0



Due to the to waste production growth and to the high requirements for its condition and sorting, the collection spots capacity must be gradually increased as well, but they are often located at places where every square meter is valuable. When using semi-underground containers, you will be able to use the collection spot space better and simultaneously improve its aesthetic appearance and cleanliness.

These containers can be even used in remote areas as their large capacity enables longer collection intervals, therefore it reduces collection costs. Their design is based on our own development taking into consideration not only their appearance but their ergonomic aspect as well.

Usage

- for selective collection of glass, paper, plastics, bio waste and residual municipal waste.

Specification

- made of polyethylene,
- all steel parts are hot dip galvanized,
- they consist of an outer silo built in the ground (1350 mm) and an internal removable cylindrical container or plastic bag.

Emptying

- into an open top roll-off containers or compaction superstructures, using an hydraulic crane,
- single/double hooks or Kinshofer systems.

Basic versions

- bag or solid plastic/steel inner container,
- standard lid of safety drum,
- outer housing Wood or Urban.

Main advantages

- considerably higher collection spot capacity,
- collection frequency reduction, leading to lower costs and reducing negative impacts on the environment (less CO2 emissions, less noise and traffic),
- most of the waste is stored below the ground level with lower and more stable temperature, slowing waste decomposition and odor reduction,
- waste is stored up to a height of 2.5 m, resulting in better compaction by its own weight,
- reduction of vandalism and the possibility of re-collecting waste, incl. access of animals,
- aesthetic appearance and cleanliness of the collection point that does not overflow with garbage.



SemiQ in the Norwegian town of Oslo



SemiQ in the ground cross section

type	SemiQ 1,5	SemiQ 3,0	SemiQ 5,0
volume [m ³]	1,5	3,0	5,0
size: diameter x h	1150 x 2510	1500 x 2700	1900 x 2770



SemiQ 1.5

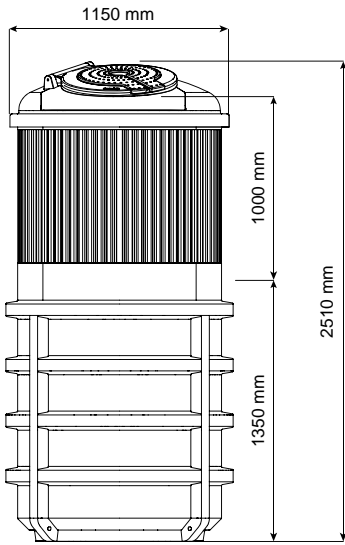

SemiQ 3.0

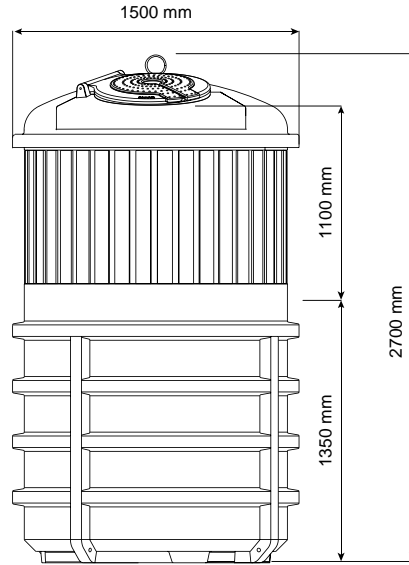

SemiQ 5.0

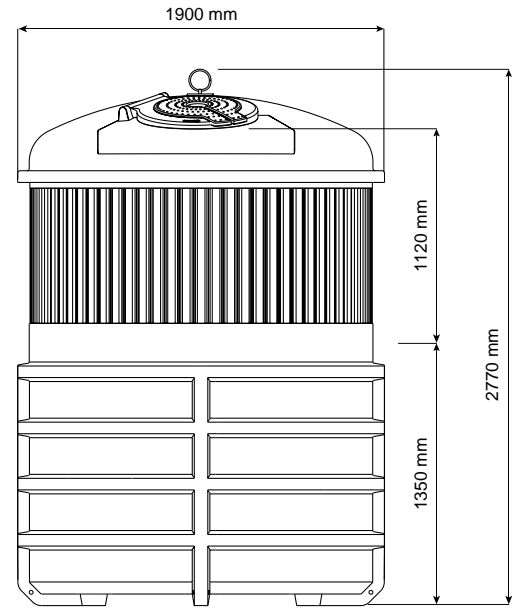

Cover types



Standard lid



Double standard lid



Security drum with a capacity of 80 l



SemiQ 1.5 and 5.0



SemiQ 5.0 Urban

Inlet openings



Ø 165 mm



Ø 180 mm



Ø 500 mm



200 x 250 mm



200 x 420 mm



SemiQ 5,0 Wood, total view



SemiQ 5,0 Urban, cross section



Internal container with two-hook system (two-part bottom)



Bag



Bag with one-part bottom



Internal container with pedal system (one-part bottom)



SemiQ 3.0 for a sorted collection in Valašské Meziříčí



SemiQ bag

Collection banks made from steel

SLD 2.0, 2.5, 3.0, 3.5, 4.0



The SLD steel waste collection banks are popular for their mechanical resistance and fire protection. Their rectangular design enables an optimal use of the collection point space.

Both the roof and the container walls are made from galvanized steel plates. The containers are reinforced by lower solid steel profiles, which are fully hot dip galvanized. Bottom flaps are hinged on the outside of the bottom frame and will resist to very high loads.. The entire container is coated with a high-quality two-component RAL color.

The inlets on both opposite sides (glass/paper type) are designed to enable safe and comfortable use, inlets for bottle collection are protected with rubber rosettes. Customized inlets are available on request.

Our solution for paper and plastic collection provides trouble-free emptying, when the emptying rods are placed along the containers walls and prevent the waste jamming during emptying.

Emptying

- by hydraulic crane directly into a waste collection truck,
- 2/3 hook system or Kinshofer type.

Options

- customized throw-in holes,
- any RAL color,
- multi-compartment design (Duo, Triglo models),
- noise reduction.

type	volume [m³]	width [mm]	depth [mm]	height [mm]
SLD 2.0	2.0	1120	1200	1600
SLD 2.5	2.5	1370	1200	1600
SLD 3.0	3.0	1630	1200	1600
SLD 3.5	3.5	1900	1200	1600
SLD 4.0	4.0	2170	1200	1600

Specification

- bolted construction enables easy parts replacement,
- extremely robust construction,
- hot-dip galvanized supporting frame, galvanized sheet metal walls and roof,
- EN 13071 certified.



SLD 3.5 TRIGLO (three-compartment container for glass)



SLD 3.5



ELKOPLAST

Between nature and human



EUROPEAN UNION
European Regional Development Fund
Operational Programme Enterprise
and Innovations for Competitiveness



ELKOPLAST CZ, s.r.o.

Štefánikova 2664
760 01 Zlín
Czech Republic
e-mail: elkoplast@elkoplast.cz
tel.: +420 575 571 000
fax: +420 575 571 099



www.elkoplast.eu